

ROBO-COUP

- **A coupling system to transmit power supply, compressed air and ICT signal**
- **Made to connect all kind of robot tools**
- **Connecting and disconnecting made fast and easy**
- **System is modular - more capacity (output) can be increased when needed**

- Repeatability: $\pm 0,05\text{mm}$
- Forces: 2.500N in all directions
- Torques: up to 1.500Nm in all directions
- Power connection (Weidmüller - Heavy duty)
 - 400V / 6 kW
 - Modular system
 - Transmission of ICT signals: network 8 pins
- Transmission of compressed air: 8bar, pneumatic 1/2"
- To connect: no additional force
- To disconnect: compressed air, max 2.5bar
- Mechanical gland: compensation of inaccuracies up to 30 mm

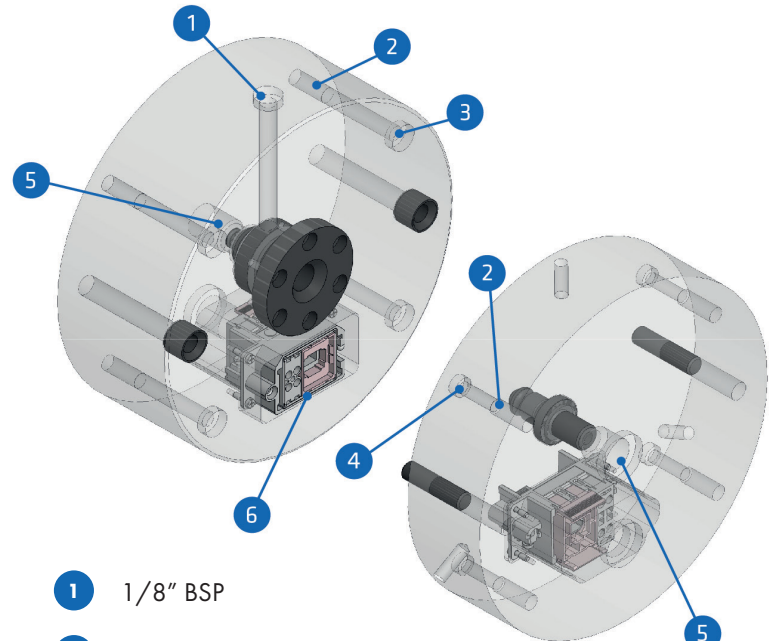

- 1 1/8" BSP
- 2 (x4) holes for M8
- 3 (x4) holes for M6X90
- 4 (x4) holes for M6X60
- 5 1/2" BSP
- 6 Weidmüller - Heavy duty

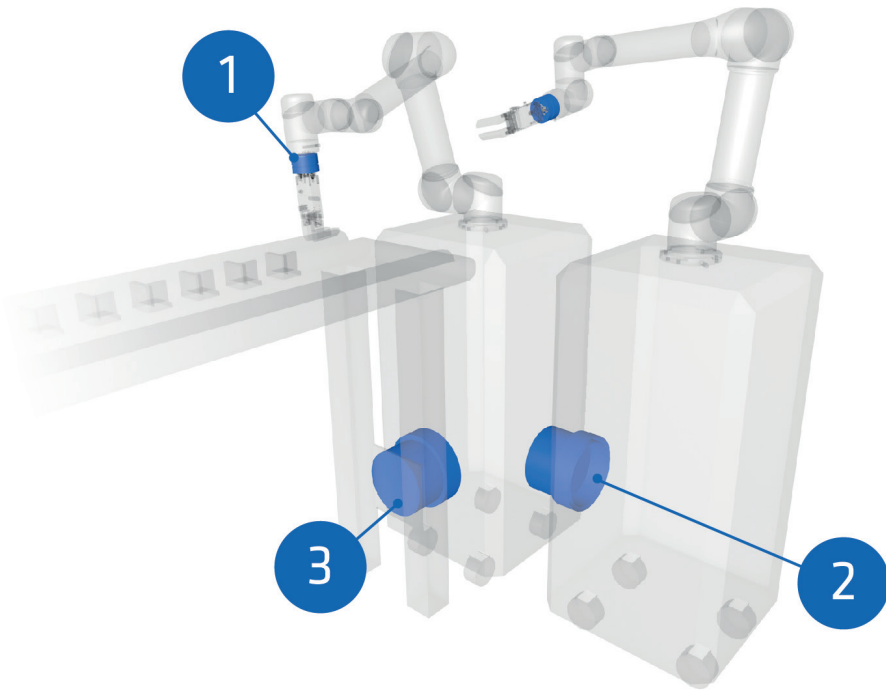

Coupling system can be used for:

- 1 Connecting robot arm with the tooling
- 2 Connecting few robot units into one system
- 3 Connecting robot unit with the third-party equipment

INGEMANN

www.robo-coup.com

DEALER

UAB Blue Ocean Robotics

Thomas Solupajev- Ronlev

Mob.: +370 685 35 145

Email: tsr@blue-ocean-robotics.com